

COS1521
RCO1521

(497174)

(497272)

May/June 2016

COMPUTER SYSTEMS: FUNDAMENTAL CONCEPTS

Duration 2 Hours

100 Marks

EXAMINERS

FIRST

SECOND

MR ME BOGOPA

MRS P LE ROUX

Closed book examination.

This examination question paper remains the property of the University of South Africa and may not be removed from the examination venue

This paper consists of 27 pages and the instructions for the completion of a mark-reading sheet

Please complete the attendance register on the back page, tear it off and hand it to the invigilator

Instructions:

- 1 All the questions in this paper are **multiple-choice**
- 2 There are 80 questions in total Your total mark out of 80 will be converted to a final exam mark out of 100
- 3 Answer all the questions There is also space for rough work
- 4 Using a pencil, answer all the questions on the mark-reading sheet
- 5 Remember to fill in the **unique number** (see top of page) on the mark-reading sheet
- 6 You are not allowed to use a calculator

EVERYTHING OF THE BEST!

[TURN OVER]

This paper consists of 80 multiple-choice questions.

Each question is worth 1 mark.

Your total out of 80 will be converted to give a final exam mark out of 100.

Mark only one alternative per question with a pencil on the mark-reading sheet.

(Remember to fill in the unique number.)

Section A: Computer background, number systems, data storage, operations on data and logic **(27 marks)**

QUESTION 1

Which subsystem of a computer is responsible for the sending of signals to other subsystems?

- 1 Memory
- 2 Arithmetic logic unit
- 3 Control unit
- 4 Input/Output

QUESTION 2

Computer science has created some peripheral issues. Privacy, copyright and computer crime are categorized as _____ issues

- 1 social
- 2 digital divide
- 3 security
- 4 ethical

QUESTION 3

Convert the decimal number $(75\ 55)_{10}$ to binary

- 1 $(101011\ 10001)_2$
- 2 $(101011\ 10010)_2$
- 3 $(101011\ 10000)_2$
- 4 $(101011\ 11000)_2$

[TURN OVER]

QUESTION 7

Which one of the following statements regarding the storing of images is TRUE?

- 1 Raster graphics is used when we need to store a digital image
- 2 The scanning rate in image processing is called resolutions
- 3 A vector graphic image store bit patterns for each pixel
- 4 Raster graphics decompose an image into a combination of geometrical shapes

QUESTION 8

Convert $(101110\ 101)_2$ to normalized form

- 1 $(10111010)_2 \times (2^5)_{10}$
- 2 $(0101110101)_2 \times (2^6)_{10}$
- 3 $(101110101)_2 \times (2^3)_{10}$
- 4 $(0101110101)_2 \times (2^6)_{10}$

QUESTION 9

Calculate $(10011001)_2$ XOR $(00101110)_2$

- 1 $(11001000)_2$
- 2 $(01001000)_2$
- 3 $(00110111)_2$
- 4 $(10110111)_2$

QUESTION 10

A mask is used to unset bits of the bit pattern 10100110 (input) What is the output if the mask 00100100 is applied?

- 1 01011001
- 2 00000100
- 3 10110101
- 4 10100110

QUESTION 11

Calculate $(1011\ 01)_2 + (111)_2$

- 1 $(1101\ 00)_2$
- 2 $(10010\ 01)_2$
- 3 $(1101\ 01)_2$
- 4 $(10010\ 10)_2$

[TURN OVER]

QUESTION 12

Calculate the simplest form of the Boolean function $AB'C + (AB'C)'D$?

- 1 $AB'C + D$
- 2 $A + B + C + D$
- 3 D'
- 4 $AB'C$

QUESTION 13

Which of the examples below expresses the associative rule of Boolean algebra?

- 1 $(x + y) + z = x + (y + z)$
- 2 $x(y + z) = xy + xz$
- 3 $x + (y + z) = xy + xz$
- 4 $x(yz) = (xy)z$

QUESTION 14

Which Boolean rule represents the Boolean function $x(x' + y) = xy$?

- 1 Commutative rule
- 2 Distributive rule
- 3 Absorption rule
- 4 Identity rule

QUESTION 15

After applying DeMorgan's theorem to the expression $[(A + B + C) D]'$, the result is

- 1 $A'B'C'D'$
- 2 $(ABC)' D$
- 3 $ABC D'$
- 4 $A'B'C' + D'$

[TURN OVER]

QUESTION 16

The following question refer to the incomplete truth table below for the expression

$$G = A'C + AB'$$

What is the expression G in sum of minterms form?

A	B	C	G	minterms	m-notation
0	0	0			m_0
0	0	1	1		m_1
				$A'BC'$	
0	1	1			m_3
1	0	0			
1	1	1			

- 1 $m_1 + m_2 + m_2$
- 2 $m_1 + m_4 + m_5$
- 3 $m_0 + m_2 + m_3$
- 4 $m_0 + m_4 + m_5$

Rough work

[TURN OVER]

The following TWO questions refer to the Karnaugh diagram below:

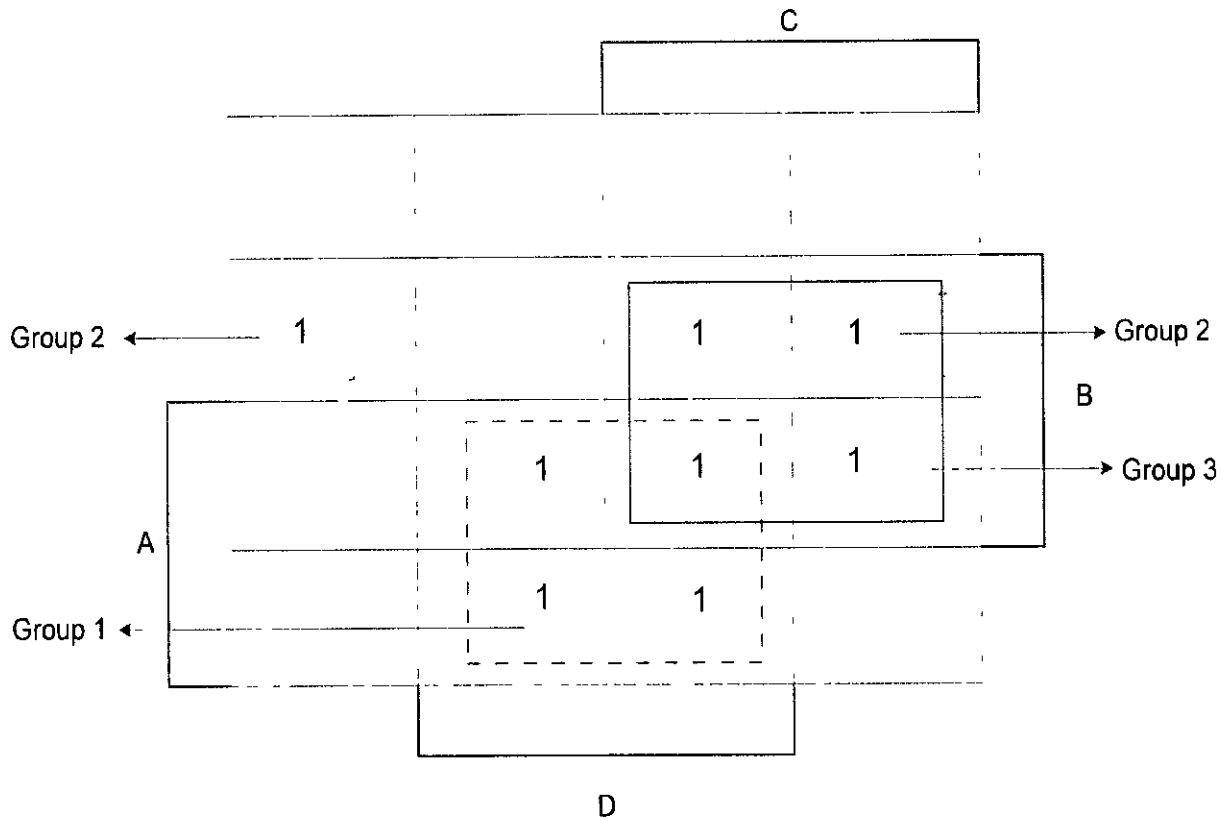

QUESTION 17

Which term represents Group 2?

- 1 B
- 2 $A'BD'$
- 3 $A'BC$
- 4 BD'

QUESTION 18

Which term represents Group 3?

- 1 $A'B$
- 2 $D'B$
- 3 BC
- 4 CBD

[TURN OVER]

QUESTION 19

Which of the Karnaugh diagrams below represents the expression $X = AC + BC + B^0$

1

	B'C'	B'C	BC	BC'
A'	1	1	1	1
A	0	0	0	0

2

	B'C'	B'C	BC	BC'
A'	0	0	0	0
A	1	1	1	1

3

	B'C'	B C	BC	BC'
A'	0	0	1	1
A	0	1	1	1

4

	B'C'	B'C	BC	BC'
A'	1	1	1	0
A	1	1	1	0

Rough work

[TURN OVER]

QUESTION 20Which logic diagram presents the logic expression BC' ?

1

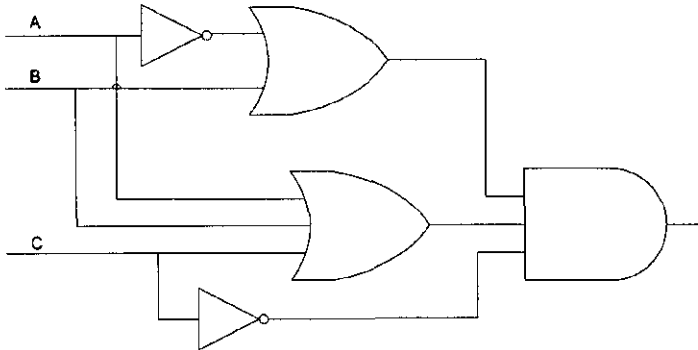

2

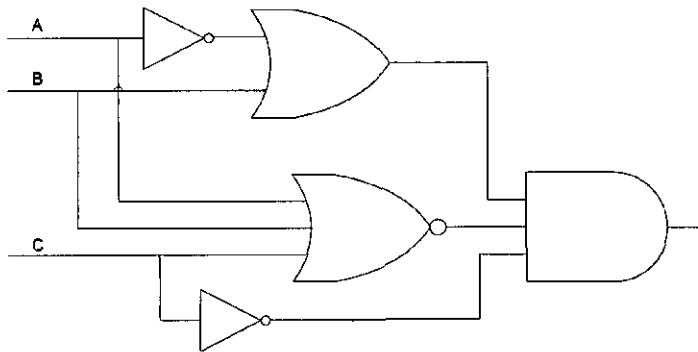

3

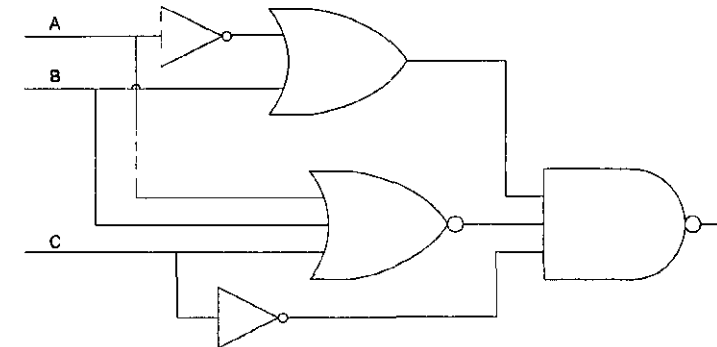

4

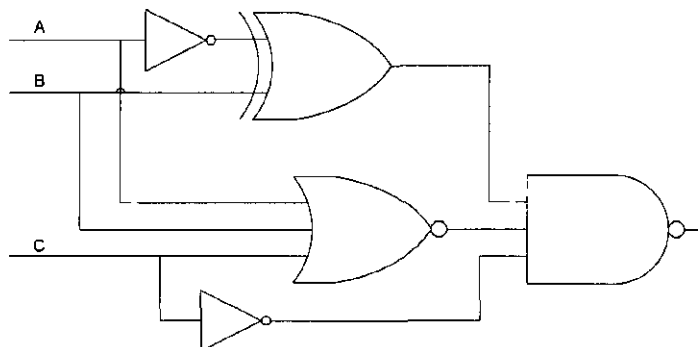
**[TURN OVER]**

Question 21, 22 and 23 refer to the following combinational logic circuit:

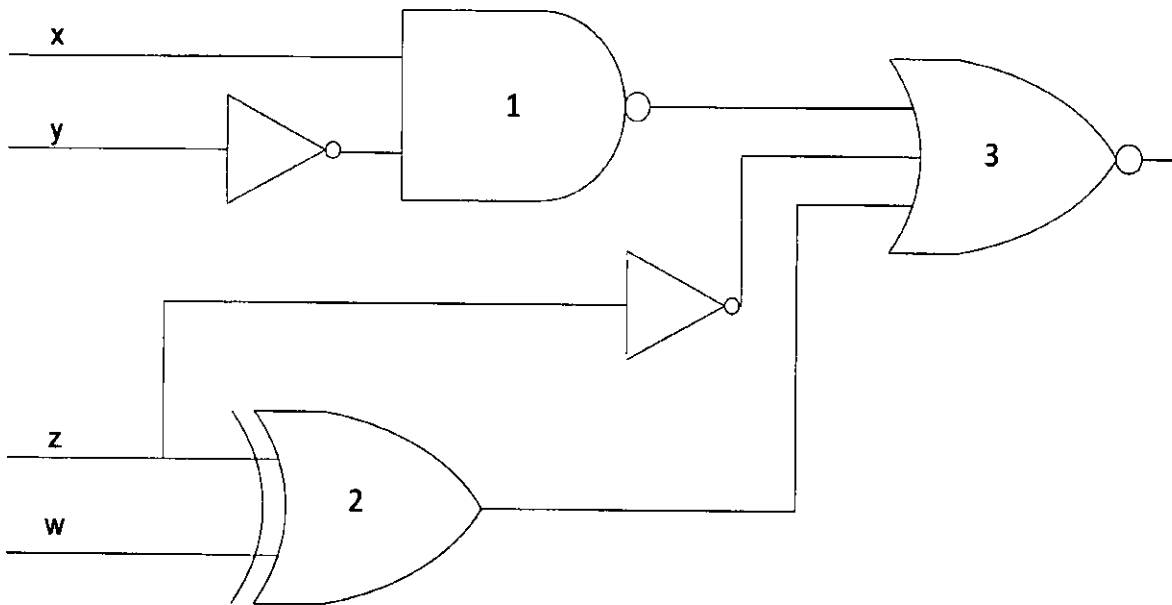

QUESTION 21

Gate 2 is an example of a _____ gate

- 1 AND
- 2 NAND
- 3 NOR
- 4 XOR

QUESTION 22

What is the output of Gate 2?

- 1 $z' \oplus w$
- 2 $z \oplus w$
- 3 $z + w$
- 4 $zw' + z'w$

QUESTION 23

What is the output of Gate 3?

- 1 $[(x' + y) + z'(z + w)]'$
- 2 $(x + y)' (z' + zw' + 'wz)'$
- 3 $[(xy)'+ z' + (z \oplus w)]'$
- 4 $[(xy)'+ z'(z' \oplus w)]'$

[TURN OVER]

Rough work

[TURN OVER]

The following FOUR questions refer to the following scenario:

Three sensors are attached to a printing device, with two alarms attached to the sensors

- The first sensor, "A," detects if the printer needs ink
- The second sensor, "B," detects if the printer needs repair
- The third sensor, "C," detects if the printer should jam

If the printer jams or needs repair, alarm 1 sounds If the printer jams or is short on ink, alarm 2 sounds

Suppose the input variables A, B and C in a truth table take on the value 1 whenever a problem is detected For example, if $A = 0$, $B = 1$ and $C = 1$, it means that the printer needs repair (B) or the printer jams (C) and alarm 1 will sounds

A Boolean function $F(A,B,C)$ is defined as follows $F(A,B,C) = 1$ when two or more problems occur at once and a zero otherwise

Different combinations inputs for A, B and C are given in the tables provided in the following FOUR questions Which alternative shows the correct outputs for F in EACH of the following FOUR questions?

QUESTION 24

			Alternative 1	Alternative 2	Alternative 3	Alternative 4
A	B	C	F	F	F	F
0	1	1	0	1	0	1
0	1	0	0	1	1	0

QUESTION 25

			Alternative 1	Alternative 2	Alternative 3	Alternative 4
A	B	C	F	F	F	F
1	1	1	0	1	0	1
1	1	0	0	1	1	0

QUESTION 26

			Alternative 1	Alternative 2	Alternative 3	Alternative 4
A	B	C	F	F	F	F
0	1	1	0	1	0	1
1	1	0	0	1	1	0

[TURN OVER]

Section B: Computer systems, organisation and networks**(18 marks)****QUESTION 28**

Which one of the following is among the three main operations performed by the arithmetic logic unit (ALU) of a computer?

- 1 Encode
- 2 Search
- 3 Scan
- 4 Shift

QUESTION 29

What is the task of the registers when the CPU needs to access a word in main memory?

- 1 Treat the input data as bit patterns
- 2 Facilitates the operations of the CPU
- 3 Controls the operation of each subsystem
- 4 Shift bit patterns to the left or right

QUESTION 30

Which one of the following statements IS NOT TRUE about auxiliary storage devices?

- 1 They are volatile
- 2 They can be magnetic
- 3 They are considered to be I/O devices
- 4 They can be optical

QUESTION 31

In the following figure the hierarchical levels of memory are provided. The costliness (A and B) and speed (C and D) with regard to the memory hierarchy are indicated by the arrowed lines in the figure. Choose the alternative that gives the correct information for A, B, C and D.

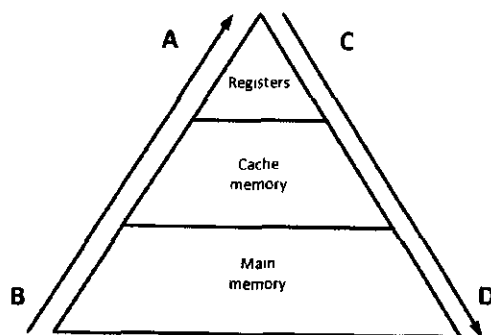

- | | | | | |
|---|----------------|----------------|------------|-----------|
| 1 | A less costly, | B more costly | C slowest, | D fastest |
| 2 | A more costly, | B less costly, | C fastest, | D slowest |
| 3 | A less costly, | B more costly, | C fastest, | D slowest |
| 4 | A more costly | B less costly, | C slowest, | D fastest |

[TURN OVER]

QUESTION 32

In the decode phase of the machine cycle, an instruction in an instruction register is decoded by the _____

- 1 ALU
- 2 control unit
- 3 memory
- 4 programmed I/O

QUESTION 33

A computer has 1024 MB of memory. Each word in this computer has 64 bytes. How many bits are needed to address any single word in memory?

- 1 25
- 2 26
- 3 23
- 4 24

QUESTION 34

Pipelining can be defined as

- 1 The simulation of complex instructions by using simple instructions
- 2 Programming to be done in two levels, *microoperations* and *microprogramming*
- 3 Processing of an instruction starts before another instruction is finished
- 4 A single computer having multiple control units, multiple logic units and multiple memory units

QUESTION 35

A host communicates with another host using the TCP/IP protocol. What is the unit of data sent or received by the application layer?

- 1 message
- 2 datagram
- 3 frame
- 4 bytes

QUESTION 36

There are several layers in the Internet TCP/IP suite. What is the transport layer responsible for?

- 1 Node-to-node delivery of frames
- 2 Delivery of individual packets from the source host to the destination host
- 3 Providing services to the user
- 4 Logical delivery of a message between client and server processes

QUESTION 37

Which of the following is NOT a component of email architecture?

- 1 MTA server
- 2 MAA client
- 3 FTP protocol
- 4 UA program

[TURN OVER]

QUESTION 38

A computer that translates _____ of another computer into a(n) _____ and vice versa, upon request is known as DNS server

- 1 Domain name and IP address
- 2 Host address and Domain name
- 3 Domain name and server address
- 4 Server name and IP address

QUESTION 39

What are the identifiers needed to define a webpage?

- 1 protocol, client, port, path
- 2 protocol, host, browser, path
- 3 protocol, host port, path
- 4 protocol, client, server, path

QUESTION 40

In _____ only one program can reside in memory for execution

- 1 monoprogramming
- 2 multiprogramming
- 3 partitioning
- 4 paging

QUESTION 41

In paging, a memory is divided into equally sized sections called _____

- 1 pages
- 2 frames
- 3 segments
- 4 partitions

QUESTION 42

Which two of the following techniques belongs to the *swapping* category?

- A Paging
- B Segmentation
- C Demand paging
- D Demand segmentation
- E Partitioning

- 1 A and B
- 2 B and C
- 3 C and D
- 4 D and E

[TURN OVER]

QUESTION 43

A process in the ready state goes to the running state when _____

- 1 it enters memory
- 2 it requests
- 3 it gets access to the CPU
- 4 it finishes running

QUESTION 44

The operating system synchronises different processes with different resources but a deadlock can occur. There are four necessary conditions for a deadlock to occur. Which of the following is the correct description of the 'NO PREEMPTION' condition?

- 1 The operating system cannot temporarily relocate a resource
- 2 Only one process can hold a resource
- 3 A process holds a resource even though it cannot use it until other resources are available
- 4 All processes and resources involved form a loop

QUESTION 45

Which ONE of the following managers is responsible for archiving and backup?

- 1 memory
- 2 process
- 3 device
- 4 file

Section C: Computer algorithms, programming and software development**(18 marks)****QUESTION 46**

A list contains the following elements

7 10 17 19 35 40 48 69 76 81 83 98 110

At the beginning, first = 1, mid = 7 and last = 13. What are the values of first, mid and last respectively after two more iterations of the binary search algorithm if the goal is 35?

- 1 1, 3, 6
- 2 2, 5, 8
- 3 4, 5, 6
- 4 7, 10, 13

[TURN OVER]

QUESTION 48

In which Sorting algorithms is the list to be sorted divided in to two sublists – sorted and unsorted, and separated by an imaginary wall?

- 1 Selection sort
- 2 Bubble sort
- 3 Insertion sort
- 4 Deletion sort

QUESTION 49

Which construct is represented by the below Pseudocode?

```
get our number  
set our initial count to 0  
while our number is greater than 1  
divide the number 2  
increase our count by 1  
end
```

- 1 Sequence
- 2 Decision
- 3 Repetition
- 4 Generalization

QUESTION 50

The way a card game player arranges his cards as he picks them up one by one, is an example of?

- 1 Bubble sort
- 2 Selection sort
- 3 Insertion sort
- 4 Merge sort

QUESTION 51

Which one of the following is a logical parts of the ‘Summation’ algorithm?

- 1 Swap the selection algorithm
- 2 Initialization of the product at the beginning
- 3 The loop, which in each iteration multiplies a new integer with the product
- 4 Return of the result after exiting from the loop

[TURN OVER]

QUESTION 52

Which language was understood by the computer hardware, and the language was made of electronic switches with two states?

- 1 Computer language
- 2 High-level language
- 3 Assembly language
- 4 Machine language

QUESTION 53

(i) _____ and (ii) _____ are both classified as object-oriented languages

- 1 (i) BASIC (ii) C#
- 2 (i) Java (ii) C
- 3 (i) C (ii) Visual Basic
- 4 (i) C++ (ii) C#

QUESTION 54

During the source code translation process, the source file goes through a series of sub-processes to its final output. In which sub-process a set of tokens are parsed to find instructions?

- 1 syntax analysis
- 2 lexical analysis
- 3 code generation
- 4 semantic analysis

QUESTION 55

What is the tool used by a programmer to convert a source program into the object program?

- 1 Compiler
- 2 Language translator
- 3 Linker
- 4 Preprocessor

QUESTION 56

Which computer programming language is known for using *prolog*?

- 1 Declarative
- 2 Functional
- 3 Procedural
- 4 Object-oriented

[TURN OVER]

QUESTION 57

Which one is a common language in the business environment?

- 1 FORTRAN
- 2 C++
- 3 C
- 4 COBOL

QUESTION 58

State whether True or False for the Incremental model

- A Software is developed in a series of steps.
B They do not add more functionality until the existing system works properly

- 1 False, False
- 2 False, True
- 3 True, False
- 4 True, True

QUESTION 59

Coupling is _____

- 1 the encapsulation of data and methods
- 2 the division of a large program into smaller parts that can communicate with each other
- 3 a measure of how tightly two modules are bound to each other
- 4 a measure of how closely the modules in a system are related

QUESTION 60

Transferability is one of the measures for software quality Transferability includes _____

- 1 portability
- 2 changeability
- 3 flexibility
- 4 efficiency

QUESTION 61

_____ is a black box testing method?

- 1 Boundary value testing
- 2 Basic path testing
- 3 Code path testing
- 4 Control structure testing

[TURN OVER]

QUESTION 62

The objective of testing phase is?

- 1 to debug software
- 2 to uncover errors
- 3 to gain modularity
- 4 to analyse system

QUESTION 63

Documentation is needed in order to use software properly and maintain it efficiently. Technical documentation

- 1 describes the installation and the servicing of the software system
- 2 defines the software itself
- 3 can be a very powerful marketing tool
- 4 shows how to use the software step by step

Section D: Computer data and files structure, and databases**(17 marks)****QUESTION 64**

All the members of a record must be _____

- 1 the same type
- 2 related type
- 3 integer type
- 4 character type

QUESTION 65

Which of the following best describes what a linked list is?

- 1 A collection of fields that are all related to one object
- 2 A sequenced collection of elements, normally of the same data type
- 3 A collection of related elements, possible of different types
- 4 A collection of data in which each element contains the location of the next element

QUESTION 66

Which of the following operations can be defined on array structures?

- A Searching
- B Deletion
- C Retrieval
- D Insertion

[TURN OVER]

Alternatives

- 1 Only A, B and C
- 2 Only B, C and D
- 3 Only A, B and D
- 4 A, B, C, and D

QUESTION 67

Given a linked list called children, the pointer variable children identifies _____ element of the linked list

- 1 first
- 2 second
- 3 middle
- 4 last

QUESTION 68

What is an ordered collection of data in which each element contains the location of the next element?

- 1 An array
- 2 A record
- 3 A linked list
- 4 A node

QUESTION 69

State whether the below two statements are True or False regarding retrieving elements

- A Retrieving means randomly accessing an element for the purpose of inspecting or copying the data contained in the element
- B Retrieving is a difficult operation when a data structure is an array

- 1 False, False
- 2 False, True
- 3 True, False
- 4 True, True

QUESTION 70

When a sequential file is updated, which file contains the changes to be applied?

- 1 new master
- 2 old master
- 3 transaction
- 4 error report

[TURN OVER]

QUESTION 71

What is the address produced by a hashing algorithm?

- 1 probe
- 2 synonym
- 3 collision
- 4 home

QUESTION 72

How many field(s) does the index of an indexed file has?

- 1 one
- 2 two
- 3 three
- 4 four

QUESTION 73

When using digit extraction hashing, selected digits are extracted from the key and used as _____

- 1 the buckets
- 2 the address
- 3 the record
- 4 the report

QUESTION 74

Which one of the following steps is NOT correct when accessing a record in the file?

- 1 The entire index file is loaded into main memory
- 2 The index entries are searched, using an efficient search algorithm such as a binary search, to find the desired key
- 3 The address of the record is retrieved
- 4 Using the address, the data record is retrieved and passed to the mapping

QUESTION 75

The data model and the schema of a DBMS are often defined at the _____ level

- 1 physical
- 2 internal
- 3 conceptual
- 4 external

[TURN OVER]

QUESTION 76

In the _____ model, the entities are organised in a graph, in which some entities can be accessed through several paths

- 1 Network
- 2 Distributed
- 3 Relational
- 4 Hierarchical

QUESTION 77

What name is given to a column of relation (table)?

- 1 Attribute
- 2 Tuple
- 3 Field
- 4 Cardinality

QUESTION 78

A binary operator is applied to _____ relations(s) and creates an output of _____ relation(s)

- 1 one, one
- 2 one, two
- 3 two, one
- 4 two, two

QUESTION 79

In a replicated distributed database, _____

- 1 data are localised
- 2 objects and their relations are defined
- 3 each site holds an exact duplication of another site
- 4 any modification to data stored in one site is repeated exactly at every site

QUESTION 80

Which of the following is a declarative language used on relational databases?

- 1 PDQ
- 2 SQL
- 3 LES
- 4 PBJ

PART 1 (GENERAL/ALGEMEEN) DEEL 1

STUDY UNIT e.g. PSY100 X
 STUDIE-EENHEID by PSY100 X

1

PAPER NUMBER
 VRAESTELNOMMER **2**

INITIALS AND SURNAME
 VOORLETTERS EN VAN **3**

DATE OF EXAMINATION
 DATUM VAN EKSAMEN **4**

EXAMINATION CENTRE (E.G. PRETORIA)
 EKSAMENSENTRUM (BY PRETORIA) **5**

STUDENT NUMBER
 STUDENTENOMMER **6**

7

UNIQUE PAPER NO.
 UNIEKE VRAESTEL NR. **8**

9

For use by examination invigilator
 Vir gebruik deur eksamenopsiener

IMPORTANT

1. USE ONLY AN HB PENCIL TO COMPLETE THIS SHEET
2. MARK LIKE THIS
3. CHECK THAT YOUR INITIALS AND SURNAME HAS BEEN FILLED IN CORRECTLY
4. ENTER YOUR STUDENT NUMBER FROM LEFT TO RIGHT
5. CHECK THAT YOUR STUDENT NUMBER HAS BEEN FILLED IN CORRECTLY
6. CHECK THAT THE UNIQUE NUMBER HAS BEEN FILLED IN CORRECTLY
7. CHECK THAT ONLY ONE ANSWER PER QUESTION HAS BEEN MARKED
8. DO NOT FOLD

BELANGRIK

1. GEBRUIK SLEGS 'N HB POTLOOD OM HIERDIE BLAD TE VOLTOOI
2. MERK AS VOLG
3. KONTROLEER DAT U VOORLETTERS EN VAN REG INGEVUL IS
4. VUL U STUDENTENOMMER VAN LINKS NA REGS IN
5. KONTROLEER DAT U DIF KORREKTE STUDENTENOMMER VERSTREK HET
6. KONTROLEER DAT DIE UNIEKE NOMMER REG INGEVUL IS
7. MAAK SEKER DAT NET EEN ALTERNATIEF PER VRAAG GEMERK IS
8. MOENIE VOU NIE

PART 2 (ANSWERS/ANTWOORDE) DEEL 2

10

1 c1) c2) c3) c4) c5)
 2 c1) c2) c3) c4) c5)
 3 c1) c2) c3) c4) c5)
 4 c1) c2) c3) c4) c5)
 5 c1) c2) c3) c4) c5)
 6 c1) c2) c3) c4) c5)
 7 c1) c2) c3) c4) c5)
 8 c1) c2) c3) c4) c5)
 9 c1) c2) c3) c4) c5)
 10 c1) c2) c3) c4) c5)
 11 c1) c2) c3) c4) c5)
 12 c1) c2) c3) c4) c5)
 13 c1) c2) c3) c4) c5)
 14 c1) c2) c3) c4) c5)
 15 c1) c2) c3) c4) c5)
 16 c1) c2) c3) c4) c5)
 17 c1) c2) c3) c4) c5)
 18 c1) c2) c3) c4) c5)
 19 c1) c2) c3) c4) c5)
 20 c1) c2) c3) c4) c5)
 21 c1) c2) c3) c4) c5)
 22 c1) c2) c3) c4) c5)
 23 c1) c2) c3) c4) c5)
 24 c1) c2) c3) c4) c5)
 25 c1) c2) c3) c4) c5)
 26 c1) c2) c3) c4) c5)
 27 c1) c2) c3) c4) c5)
 28 c1) c2) c3) c4) c5)
 29 c1) c2) c3) c4) c5)
 30 c1) c2) c3) c4) c5)
 31 c1) c2) c3) c4) c5)
 32 c1) c2) c3) c4) c5)
 33 c1) c2) c3) c4) c5)
 34 c1) c2) c3) c4) c5)
 35 c1) c2) c3) c4) c5)

36 c1) c2) c3) c4) c5)
 37 c1) c2) c3) c4) c5)
 38 c1) c2) c3) c4) c5)
 39 c1) c2) c3) c4) c5)
 40 c1) c2) c3) c4) c5)
 41 c1) c2) c3) c4) c5)
 42 c1) c2) c3) c4) c5)
 43 c1) c2) c3) c4) c5)
 44 c1) c2) c3) c4) c5)
 45 c1) c2) c3) c4) c5)
 46 c1) c2) c3) c4) c5)
 47 c1) c2) c3) c4) c5)
 48 c1) c2) c3) c4) c5)
 49 c1) c2) c3) c4) c5)
 50 c1) c2) c3) c4) c5)
 51 c1) c2) c3) c4) c5)
 52 c1) c2) c3) c4) c5)
 53 c1) c2) c3) c4) c5)
 54 c1) c2) c3) c4) c5)
 55 c1) c2) c3) c4) c5)
 56 c1) c2) c3) c4) c5)
 57 c1) c2) c3) c4) c5)
 58 c1) c2) c3) c4) c5)
 59 c1) c2) c3) c4) c5)
 60 c1) c2) c3) c4) c5)
 61 c1) c2) c3) c4) c5)
 62 c1) c2) c3) c4) c5)
 63 c1) c2) c3) c4) c5)
 64 c1) c2) c3) c4) c5)
 65 c1) c2) c3) c4) c5)
 66 c1) c2) c3) c4) c5)
 67 c1) c2) c3) c4) c5)
 68 c1) c2) c3) c4) c5)
 69 c1) c2) c3) c4) c5)
 70 c1) c2) c3) c4) c5)

71 c1) c2) c3) c4) c5)
 72 c1) c2) c3) c4) c5)
 73 c1) c2) c3) c4) c5)
 74 c1) c2) c3) c4) c5)
 75 c1) c2) c3) c4) c5)
 76 c1) c2) c3) c4) c5)
 77 c1) c2) c3) c4) c5)
 78 c1) c2) c3) c4) c5)
 79 c1) c2) c3) c4) c5)
 80 c1) c2) c3) c4) c5)
 81 c1) c2) c3) c4) c5)
 82 c1) c2) c3) c4) c5)
 83 c1) c2) c3) c4) c5)
 84 c1) c2) c3) c4) c5)
 85 c1) c2) c3) c4) c5)
 86 c1) c2) c3) c4) c5)
 87 c1) c2) c3) c4) c5)
 88 c1) c2) c3) c4) c5)
 89 c1) c2) c3) c4) c5)
 90 c1) c2) c3) c4) c5)
 91 c1) c2) c3) c4) c5)
 92 c1) c2) c3) c4) c5)
 93 c1) c2) c3) c4) c5)
 94 c1) c2) c3) c4) c5)
 95 c1) c2) c3) c4) c5)
 96 c1) c2) c3) c4) c5)
 97 c1) c2) c3) c4) c5)
 98 c1) c2) c3) c4) c5)
 99 c1) c2) c3) c4) c5)
 100 c1) c2) c3) c4) c5)
 101 c1) c2) c3) c4) c5)
 102 c1) c2) c3) c4) c5)
 103 c1) c2) c3) c4) c5)
 104 c1) c2) c3) c4) c5)
 105 c1) c2) c3) c4) c5)

106 c1) c2) c3) c4) c5)
 107 c1) c2) c3) c4) c5)
 108 c1) c2) c3) c4) c5)
 109 c1) c2) c3) c4) c5)
 110 c1) c2) c3) c4) c5)
 111 c1) c2) c3) c4) c5)
 112 c1) c2) c3) c4) c5)
 113 c1) c2) c3) c4) c5)
 114 c1) c2) c3) c4) c5)
 115 c1) c2) c3) c4) c5)
 116 c1) c2) c3) c4) c5)
 117 c1) c2) c3) c4) c5)
 118 c1) c2) c3) c4) c5)
 119 c1) c2) c3) c4) c5)
 120 c1) c2) c3) c4) c5)
 121 c1) c2) c3) c4) c5)
 122 c1) c2) c3) c4) c5)
 123 c1) c2) c3) c4) c5)
 124 c1) c2) c3) c4) c5)
 125 c1) c2) c3) c4) c5)
 126 c1) c2) c3) c4) c5)
 127 c1) c2) c3) c4) c5)
 128 c1) c2) c3) c4) c5)
 129 c1) c2) c3) c4) c5)
 130 c1) c2) c3) c4) c5)
 131 c1) c2) c3) c4) c5)
 132 c1) c2) c3) c4) c5)
 133 c1) c2) c3) c4) c5)
 134 c1) c2) c3) c4) c5)
 135 c1) c2) c3) c4) c5)
 136 c1) c2) c3) c4) c5)
 137 c1) c2) c3) c4) c5)
 138 c1) c2) c3) c4) c5)
 139 c1) c2) c3) c4) c5)
 140 c1) c2) c3) c4) c5)

Specimen only