

UNIVERSITY EXAMINATIONS

UNIVERSITEITSEKSAMENS



APY1501

(482231)

May/June 2015

**THE ANTHROPOLOGICAL STUDY OF CULTURE IN A MULTICULTURAL
CONTEXT**

Duration 2 Hours

60 Marks

EXAMINERS

FIRST

MR JS VAN WYK

SECOND

MS JMF WOUTERS

Closed book examination

This examination question paper remains the property of the University of South Africa and may not be removed from the examination venue

APY1501

(482231)

May/June 2015

**THE ANTHROPOLOGICAL STUDY OF CULTURE IN A MULTICULTURAL
CONTEXT**

Duration 2 Hours

60 Marks

EXAMINERS

FIRST

MR JS VAN WYK

SECOND

MS JMF WOUTERS

Closed book examination

This examination question paper remains the property of the University of South Africa and may not be removed from the examination venue

This paper consists of 17 pages **PLUS** instructions for the completion of a mark reading sheet

**PLEASE COMPLETE THE ATTENDANCE REGISTER ON THE BACK PAGE, TEAR OFF
AND HAND TO THE INVIGILATOR**

- 1 Answer **ALL** the questions **FILL IN YOUR ANSWERS ON THE MARK READING SHEET**
- 2 **ONLY ONE** option per multiple choice questions must be selected **NO MARKS** will be given if more than one option is included in an answer
- 3 All multiple choice questions count **ONE MARK PER QUESTION**

QUESTION 1

Select the option that **CORRECTLY** completes the following statement

Sociocultural anthropologists focus on the

- 1 relation between language and the other aspects of the life of a society
- 2 lifestyles of the rich diversity of societies as they are found worldwide
- 3 influence of biological and hereditary characteristics on behaviour of members of a society
- 4 material remains of societies which are collected during excavation of sites where people once lived

QUESTION 2

Select the option that **CORRECTLY** completes the following statement

Initially what **distinguished** anthropology from sociology was that

- 1 anthropology studied "preliterate" people
- 2 sociology studied "preliterate" people
- 3 anthropology used questionnaires for the purpose of research
- 4 sociology used qualitative research strategies to study people

QUESTION 3

Choose the **INCORRECT** statement

Linguistic anthropologists

- 1 initially studied the historical development of unwritten languages of non-western societies
- 2 study societies to gain an understanding of how cultural phenomena are expressed verbally
- 3 mainly focus attention on the evolution of languages in prehistorical societies
- 4 study the way in which language is used in different social contexts

QUESTION 4

Within the "four fields" paradigm sociocultural anthropology and archaeology are closely related in that they both reveal hidden aspects of human culture. Which of the following is **CORRECT**?

- 1 Sociocultural anthropologists are able to reveal hidden aspects about the prehistory of human populations by looking at material objects hidden beneath the earth's surface
- 2 Archaeologists perform excavations among others in order to understand, among others, the prehistory of human populations
- 3 Sociocultural anthropologists are concerned with biological and physical aspects of humans and how they have developed over time
- 4 Archaeologists concern themselves with studying the relationship between language and other aspects of people's lives in order to understand their origin

QUESTION 5

Select the option that **CORRECTLY** completes the following statement

An **holistic approach** to the study of culture means that anthropologists

- 1 attempt to obtain an overall impression of the development of culture
- 2 draw generalisations about the human condition
- 3 study the cultural systems of societies within a global cultural pattern
- 4 study all facets of human life, including the environmental factors to which people must adapt for survival

QUESTION 6

The original site for fieldwork in anthropology was the remote 'tribal' village. This narrow conception of 'field' has since been broadened. Which of the following are **now** considered **anthropological research sites** as well?

- a Drug dealers
- b Factory workers
- c Institutional settings
- d Religious movements

Choose the **CORRECT** option

- 1 a and b
- 2 a, b and d
- 3 c and d
- 4 a, b, c and d

QUESTION 7

Indicate the option that **CORRECTLY** completes the following statement

Participant observation means that an anthropologist should

- 1 participate in the sense that he/she should commit his/her thoughts and emotions to the real-world fieldwork setting, and record his/her observations in an objective, scientific and systematic manner
- 2 become an active participant in the daily life of the community concerned and report on his/her experiences from his/her own cultural perspective
- 3 be a careful observer of the customs and daily life of a community to enable him/her to understand and record the relevant activities and events
- 4 observe more than participate in a conscious attempt to obtain concise, objective answers to research questions to enable anthropological theorisation

QUESTION 8

Indicate the option that **CORRECTLY** completes the following statement

Anthropological information that has been collected by means of the ethnographic method will be regarded as a more **meaningful** and **accurate** representation of peoples' sociocultural systems when an anthropologist has

- 1 representative statistical surveys that verify the information
- 2 made systematic and relevant cross-cultural comparisons of the information
- 3 interviewed a number of research participants and has participated in relevant cultural activities
- 4 applied the emic and etic research approaches during his/her fieldwork

QUESTION 9

Indicate the option that **CORRECTLY** completes the following statement

If an excessively **cultural relativistic** approach is followed in anthropology

- 1 cultural practices that have a harmful impact on a society may not be questioned
- 2 the researcher might adopt an ethnocentric approach to the study of people
- 3 statistical data relevant to an investigation might be misinterpreted
- 4 the researcher's beliefs may influence the results of his/her investigation

QUESTION 10

Which one of the options **best** illustrates an **etic approach** to the study of the Karretjie People?

- 1 A researcher receiving the credit for publications on the Karretjie People without giving credit to his/her research participants' intellectual property
- 2 A researcher publishing information on the subjective experiences of the Karretjie People, using only their own words and phrases
- 3 A researcher presenting stereotypes of the Karretjie People as the truth, such as that they are all sly and shifty
- 4 A researcher presenting only his/her own interpretation of the information obtained from the Karretjie People

QUESTION 11

Since the 1970s anthropologists have increasingly contemplated their own role and experiences in the field. Which of the following developments are **NOT** considered to be part of this contemplation?

- 1 Multivocality
- 2 Reflexivity
- 3 Cultural relativism
- 4 Narrative ethnography

QUESTION 12

Which one of the following **best** illustrates how an application of the concept of cultural relativism influences the work of anthropologists?

- 1 An anthropologist determines which one of two social groups has developed a more effective approach to combating crime
- 2 An anthropologist compares the social structure and social behaviour of different social groups
- 3 An anthropologist interprets the behaviour of people in terms of the sociocultural context in which the behaviour is found
- 4 An anthropologist demonstrates how a social group's culture has been influenced by other social groups with which it has been in contact

QUESTION 13

Indicate the option that **CORRECTLY** completes the following statement

All of the following perspectives or approaches are characteristic of anthropology, **EXCEPT**

- 1 an holistic approach which takes the entire sociocultural and environmental settings of a human population, as well as the dynamic interaction between them into account
- 2 an experimental method of research which enables anthropologists to test human subjects under laboratory conditions to determine their strengths and weaknesses
- 3 a worldwide scope that is not bound by time
- 4 a comparative approach that brings similarities and differences between human populations to the fore

QUESTION 14

De Jongh (2010) applies the anthropological method to consider issues faced by the Karretjie People in terms of their formal education. After making an intervention to provide a sustainable process for the provision of holistic education he made a number of conclusions, which of the following are **included** in this?

- a Participatory research has to inform solutions to rural poverty and its accompanying educational challenges
- b It is necessary to make case- and context-specific decisions to address educational challenges in rural settings
- c Government alone should be responsible for implementing solutions to educational challenges in rural areas because ultimately only it has the power to do anything
- d It is necessary to understand who the people are and how they live for solutions to be effective

Choose the **CORRECT** options

- 1 a, b, c and d
- 2 a and d
- 3 b, c and d
- 4 a, b and d

QUESTION 15

Which of the following is **NOT** applicable to the anthropologist's involvement in development projects?

- 1 Providing technical information on the geographical area targeted for the development project
- 2 Doing social impact studies to avoid disrupting the local community during the implementation of a project
- 3 Co-operating with other scientists as part of a multidisciplinary team which is planning a development project
- 4 Acting as a mediator between the local community and the planners of a project

QUESTION 16

Indicate the option that **CORRECTLY** completes the following statement

The species _____ lived in camps of piled stone or bushes, had a highly developed toolkit and, possibly, the use of fire

- 1 *Australopithecus afarensis*
- 2 *Homo erectus*
- 3 *Australopithecus africanus*
- 4 *Homo habilis*

QUESTION 17

From the options below, select the species that **CORRECTLY** complete(s) the following statement

The species _____ developed speech and language, marriage and family life

- 1 *Homo sapiens*
- 2 *Homo erectus*
- 3 *Homo neanderthalensis*
- 4 *Homo habilis*
- 5 All of the above

QUESTION 18

Many human population groups around the world that are physically different also display different social behaviours. Which of the following explains this phenomenon?

- a People learn culture as they grow up. For instance, the children of the Karretjie People acquire knowledge peculiar to their lifestyle and environment within the family unit.
- b Different racial groups have different social behaviours.
- c Recent studies into the genes of people have determined that specific genes are responsible for certain behaviours.
- d Inequality plays a role. In South Africa, for instance, black people have historically had unequal access to certain facilities. The consequence of this is that they participate less frequently than white people in sports such as swimming despite the fact they are the numerical majority.

Choose the **CORRECT** combination.

- 1 b and d
- 2 a and d
- 3 b and c
- 4 a, b, c and d

QUESTION 19

According to **Dan Brown**, which of the following body modifications represents a **rite of passage** shared by millions of people in the modern age?

- 1 Amputation of limbs
- 2 Body piercing
- 3 Tattooing
- 4 Dieting

QUESTION 20

Female genital mutilation is a way of permanently marking the body. Which of the following are **INCORRECT** with regard to this practice?

- a Often enforced by older women
- b Is done for hygienic reasons
- c Is done to enhance sexual pleasure
- d Is supported by the International Bill of Human Rights

Choose the **CORRECT** option.

- 1 c and d
- 2 a, b and c
- 3 b, c and d
- 4 a, c and d

QUESTION 21

Which of the following statements regarding **body language** is **CORRECT**?

- a Full understanding of verbal messages is only possible with the aid of body language
- b It has been established that people in all societies nod their heads while saying "yes"
- c Societies world-wide have different norms with regard to the use of personal space
- d In Spain, England and the USA people stand close to each other, and even touch, when talking

Choose the **CORRECT** option

- 1 a, c and d
- 2 a and d
- 3 c and d
- 4 a, b, c and d
- 5 a and c

QUESTION 22

Choose the **CORRECT** definition for the following

Enculturation

- 1 refers to the human ability and capacity to imitate and learn from the environment
- 2 means that human behaviour is both inherited or instinctive and learned
- 3 is the way culture is transmitted or carried over from one generation to the next
- 4 refers to the acquisition of knowledge through informal learning activities only

QUESTION 23

Indicate the option that **CORRECTLY** completes the following statement

The British anthropologist, Sir Edward Tylor, who formulated one of the first definitions of the concept of culture from an anthropological perspective, defined it as

- 1 that complex whole which includes all human institutions and ways of being acquired by a person as a member of society
- 2 the ideas, thought patterns, values, attitudes and perceptions of members of society that direct and influence their behaviour
- 3 sets of relationships and behaviour patterns which are established by interacting individuals in a particular sociocultural context
- 4 the works and practices of intellectual and especially artistic activity

QUESTION 24

Indicate the option that **CORRECTLY** completes the following statement

For behaviour to be regarded as '**cultural**', it must be

- 1 characteristic of only one social group
- 2 considered to be appropriate by a significant number of people in a group
- 3 practised by every single person in a group
- 4 learned from family and friends

QUESTION 25

The word culture has many different meanings. Some academics, including anthropologists, suggest that it is no longer a valid concept and should not be used in scholarly works. According to Eriksen (2004), which of the following is a **basic objection** to the use of the **concept of culture**?

- 1 All people don't have culture
- 2 People are different and the concept of culture encourages the view that they are similar
- 3 The concept of culture highlights too many complexities in society and makes it difficult for academics to do their work
- 4 The plural of culture (cultures) divides human beings in that it emphasises differences between groups of people

QUESTION 26

Indicate the option that **CORRECTLY** completes the following statement

The appointment or recognition of a leader or an authoritative body which makes rules and laws and which is accepted and obeyed gives rise to a community's

- 1 social system
- 2 legal system
- 3 political system
- 4 military system

QUESTION 27

Which of the following statements regarding **the construction of individual and group identities** is/are **CORRECT**?

- a Identity is not a static category but a continuous process and more accurately could be called identification
- b "Politics of identity" refers to a process through which a government attempts to mould ethnic identities into relatively fixed frames so that they can act politically
- c "Identity politics" refers to a process in which ethnic and racial identities contest the structures of power that constrain them
- d Physical characteristics are important in defining an ethnic group

Choose the **CORRECT** option

- 1 a and c
- 2 a, b, c and d
- 3 a and d
- 4 b, c and d
- 5 a

QUESTION 28

According to Joshi (2009) 'cyberspace' is a new arena where the idea of identity is playing itself out. Which of the following statements makes 'cyberspace' different from other arenas where identity can be studied according to her?

- a While the internet is a new platform on which to communicate it has not introduced societies to a different way of performing identity
- b Self-identity can be explored without the constraints of 'real life' boundaries
- c Social networking is an example where the self can be explored in an altered form
- d Social science research cannot be conducted in 'cyberspace' because it is not a real 'place'

Choose the **CORRECT** combination

- 1 a and d
- 2 a, c and d
- 3 b and c
- 4 b and d

QUESTION 29

Which of the statements regarding **anthropology and gender** is/are **CORRECT**?

- a Anthropology focuses on how ideas about gender are constructed in different sociocultural contexts
- b Gender differences are located in the physical body, therefore anthropology does not distinguish between sexed bodies and socially constructed genders
- c Individuals' gender construction is viewed as occurring separately from the influence of the group's perceptions of gender
- d Gender identity is acquired through socialisation and enculturation, but is also shaped by a person's lived experiences

Choose the **CORRECT** combination

- 1 d
- 2 a and d
- 3 b and d
- 4 a and c

QUESTION 30

Which of the following may be used to distinguish an **ethnic group**?

- a A common geographical area
- b A group's own sense of identity
- c A common language
- d Songs

Choose the **CORRECT** option

- 1 b and d
- 2 c and d
- 3 a, b, c and d
- 4 b, c and d
- 5 a, b and c

QUESTION 31

Indicate the option that **CORRECTLY** completes the following statement

When anthropologists conduct research they often study how people organise their relationships in society. One of the most basic ways to do this is to look at the society's

- 1 political organisation
- 2 kinship system
- 3 judicial system
- 4 religious system

QUESTION 32

Indicate the option that **CORRECTLY** completes the following statement

In anthropology the term **effective kin** refers to

- 1 all kin who can be indicated genealogically in a family tree
- 2 only those kin with whom a person actually has some or other relationship
- 3 only those kin who can inherit property in accordance with their genealogical rank
- 4 all kin who trace their descent from a common ancestor or ancestress

QUESTION 33

Indicate the **INCORRECT** statement

Kinship diagrams can be used by anthropologists to

- 1 gain insight into whom a person is supposed to marry in Sotho-speaking societies
- 2 conclude who would officiate as ritual leader during a ritual among certain societies
- 3 visually represent where and with whom a newly married couple should live in patrilineal societies
- 4 verify the genealogical descent of clan members from their common ancestor

ANSWER QUESTIONS 34 TO 41 WITH REFERENCE TO THE FOLLOWING DIAGRAM
--

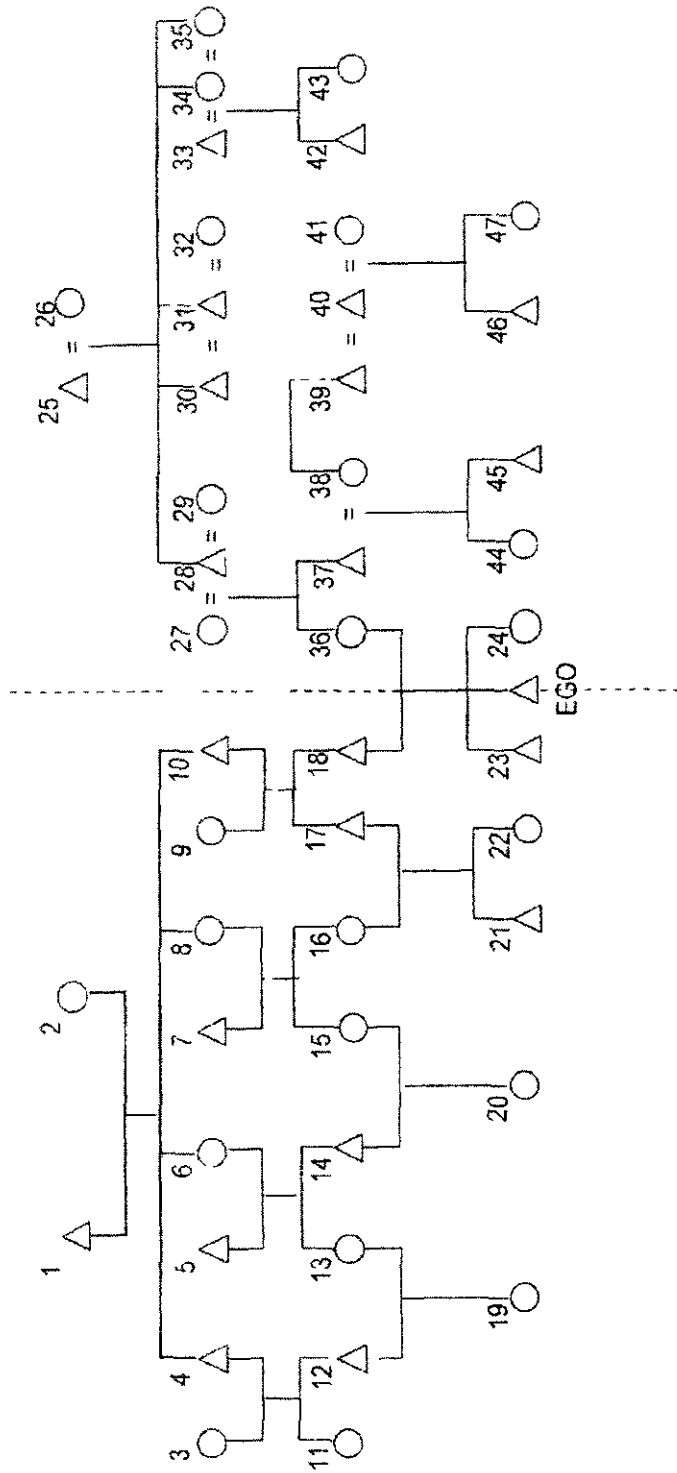

QUESTION 34

Who is the apical ancestor of the matrilineage to whom 23 belongs?

- 1 26
- 2 25
- 3 27
- 4 29

QUESTION 35

Which of the following indicates the relationship of 15 and 9 CORRECTLY?

- 1 FaBrWi
- 2 MoSiHu
- 3 FaSiDa
- 4 MoBrWi

QUESTION 36

Through whom would Ego trace descent in a cognatic descent system?

- 1 1, 4, 5, 7 and 10 as well as 25, 28, 30, 31 and 34
- 2 36, 37, 27, 28, 29, 25 and 26
- 3 18, 10, 9, 1 and 2 as well as 36, 28, 27, 25 and 26
- 4 18, 10, and 1 as well as 36, 27, 29 and 26

QUESTION 37

Who would exercise authority over EGO and 24 if they are members of a group with a matrilineal descent system?

- 1 18
- 2 37
- 3 27
- 4 36

QUESTION 38

From the options below, select the relationship that CORRECTLY completes the following statement

38 is a(n) _____ of 43

- 1 parallel-cousin
- 2 matrilineal kin
- 3 cross-cousin
- 4 affine

QUESTION 39

Which of the following persons is a cross-cousin of 20?

- 1 21
- 2 19
- 3 EGO
- 4 11

QUESTION 40

Which of the following represents a **parallel-cousin marriage**? The union between

- 1 31 and 32
- 2 16 and 17
- 3 12 and 13
- 4 14 and 15

QUESTION 41

Indicate the option that **CORRECTLY** completes the following statement

If **EGO** and **24** belong to different descent groups, their system of descent reckoning is known as

- 1 cognatic or bilateral
- 2 double
- 3 matrilineal
- 4 parallel
- 5 patrilineal

QUESTION 42

Which one of the following statements concerning **exogamy** is **CORRECT**?

- 1 Exogamy is synonymous with incest because both prohibit marriage between certain categories of kin in societies
- 2 The rules of exogamy regulate and preserve the sexual relations between clan and lineage members
- 3 Exogamy is a prohibition on marriage within a particular group such as a clan or a lineage
- 4 Exogamy is a phenomenon which is found among all Xhosa- and Sotho-speaking groups of South Africa

QUESTION 43

Indicate the option that **CORRECTLY** completes the following statement

The term **polyandry** refers to

- 1 a marital arrangement that involves the continuation of a dead woman's marriage by her sister
- 2 a very rare domestic arrangement where multiple men and women share the same household as spouses
- 3 a marriage where a man is married to more than one woman
- 4 a marriage where a woman is married to more than one man

QUESTION 44

Which one of the following applies to a **leviratic union** among indigenous groups in South Africa?

- 1 It is a continuation of a deceased man's marriage by his brother or close male relative
- 2 It is practised by all indigenous groups in South Africa
- 3 A deceased man's marriage must first be dissolved before a leviratic union can be concluded
- 4 It is concluded on behalf of a man who died before he could marry

QUESTION 45

Which one of the **patterns of residence after marriage** is usually practised in patrilineal societies?

- 1 Uxorilocal residence
- 2 Virilocal residence
- 3 Avunculocal residence
- 4 Neolocal residence
- 5 Bilocal residence

QUESTION 46

Indicate the option that **CORRECTLY** completes the following statement

All of the following are possible grounds for dissolution of marriage among **indigenous groups in South Africa**, **EXCEPT**

- 1 accusations of witchcraft
- 2 ill-treatment
- 3 the death of the husband
- 4 adultery

QUESTION 47

Select the option that **CORRECTLY** completes the following statement

Anthropologists study **religion**

- 1 in order to understand a religious system in terms of its meaning for its followers
- 2 in terms of their own standards and value systems
- 3 to make a factual evaluation of the supernatural world
- 4 to distinguish between religion and magic in small-scale communities

QUESTION 48

Indicate the option that **CORRECTLY** completes the following statement

The view that **religion** originated in response to the universal need to find comfort **in times of crises**, was formulated by

- 1 Emile Durkheim
- 2 Edward Tylor
- 3 Bronislaw Malinowski
- 4 Anthony Wallace

QUESTION 49

Indicate the option that **CORRECTLY** completes the following statement

The definition of religion as "**belief in spiritual beings**" was formulated by

- 1 Anthony Wallace
- 2 Sigmund Freud
- 3 Melvin Ember
- 4 Edward Tylor

QUESTION 50

Different meanings are attached to totemism. Which of the following apply?

Totemism

- a is usually associated with unilineal descent groups
- b may be related to the namegiving of clans and lineages
- c may be closely linked to the well-being of descent groups
- d is usually associated with prohibitions and avoidances (taboos)

Choose the **CORRECT** option

- 1 b and c
- 2 a and d
- 3 b, c and d
- 4 a, b, c and d

QUESTION 51

Choose the **CORRECT** option for the following

What is the difference between a **fetish** and an **amulet**?

- 1 A fetish is an object which is used for protection against misfortune while an amulet contains various ingredients by means of which a spirit is induced to dwell in it so that its potency can be evoked
- 2 A fetish is an object to which supernatural powers are ascribed in some societies while an amulet is intended to secure strength, health and good fortune
- 3 A fetish may be used for the purpose of success in war while an amulet is specifically worn as a piece of adornment with which to seduce the opposite sex
- 4 They are the same in terms of composition and style. The difference lies in the context in which they are used. It is called a fetish when the wearer needs protection during a fist fight. It is called an amulet when a spirit is induced to dwell in it to ward off witchcraft

QUESTION 52

Indicate the option that **CORRECTLY** completes the following statement

In anthropological theory the **concept of myth** is used to refer to

- 1 tales of fictitious events based on irrational ideas
- 2 a primitive form of scientific thinking
- 3 tales of cosmic origins and their meanings
- 4 oral tradition of verifiable historical events

QUESTION 53

Indicate the option that **CORRECTLY** completes the following statement

When a person is **possessed by a spirit** and **communicates** with other people in a strange voice or language, we refer to this as

- 1 mediumship
- 2 negative possession
- 3 positive possession
- 4 trance

QUESTION 54

The most important characteristic distinguishing a **witch** from a **sorcerer** is that a **witch**

- 1 learns his/her evil magical powers
- 2 uses words or actions to harm people
- 3 uses fetishes to perform his/her malevolent practices
- 4 has an inherent (inborn) power to harm people

QUESTION 55

Indicate the option that **CORRECTLY** completes the following statement

Religion as distinguished from **magic** is associated with

- 1 an impersonal power and an attitude of dependence
- 2 personalised spiritual beings and an attitude of manipulation
- 3 an impersonal power and an attitude of manipulation
- 4 personalised spiritual beings and an attitude of dependence

QUESTION 56

Which one of the following **ritual leaders** is commanded by the supernatural to speak on its behalf, 'announcing the will of the supernatural'?

- 1 Priest
- 2 Shaman
- 3 Prophet
- 4 Traditional healer
- 5 Diviner

QUESTION 57

Which one of the following is an **impersonal power** that works in living beings as well as non-living objects?

- 1 *Umlaza*
- 2 *Mana*
- 3 *Umkhondo*
- 4 *Malopo*

QUESTION 58

Which of the following refer to phenomena that are characteristic of the *malopo-cult*?

- 1 Possession - purification - dancing
- 2 Trance - mediumship - familiars
- 3 Purification - fetishism - mediumship
- 4 Shamanism - possession - mana

QUESTION 59

First decide whether Statements A, B and C which relate to **the meaning of rituals** are **CORRECT** or **INCORRECT** and then choose the **CORRECT** option from those given below

Statement A

Rituals contain a symbolic element

Statement B

Water is associated with coolness and purification

Statement C

The purpose of rituals may be the establishment, maintenance or restoration of relations with the supernatural

- 1 Only Statements A and B are correct
- 2 Only Statements A and C are correct
- 3 Only Statement A is correct
- 4 Only Statement B is correct
- 5 Statements A, B and C are correct

QUESTION 60

Indicate the option that **CORRECTLY** completes the following statement

Religious fundamentalism

- 1 is when people properly follow the tenets of their religions
- 2 reflects a belief that the principles on which the larger religion is based have been corrupted
- 3 is when religionists insist their states should be secular and are willing to engage in armed conflict if this is not the case
- 4 is a ritualistic practice where people from different religions come together to discuss their problems so that a solution can be found

TOTAL: [60]

PART 1 (GENERAL/ALGEMEEN) DEEL 1

STUDY UNIT e.g. PSY100-X
STUDIE EENHEID by PSY100-X

--	--	--	--	--	--	--	--

PAPER NUMBER
VRAESTELNOMMER

--	--	--	--	--	--	--	--

(0)	(0)	(0)	(0)	(0)	(0)	(0)	(0)
(1)	(1)	(1)	(1)	(1)	(1)	(1)	(1)
(2)	(2)	(2)	(2)	(2)	(2)	(2)	(2)
(3)	(3)	(3)	(3)	(3)	(3)	(3)	(3)
(4)	(4)	(4)	(4)	(4)	(4)	(4)	(4)
(5)	(5)	(5)	(5)	(5)	(5)	(5)	(5)
(6)	(6)	(6)	(6)	(6)	(6)	(6)	(6)
(7)	(7)	(7)	(7)	(7)	(7)	(7)	(7)
(8)	(8)	(8)	(8)	(8)	(8)	(8)	(8)
(9)	(9)	(9)	(9)	(9)	(9)	(9)	(9)

INITIALS AND SURNAME
VOORLETTERS EN VAN

DATE OF EXAMINATION
DATUM VAN EKSAMEN

EXAMINATION CENTRE (E.G. PRETORIA)
EKSAMENSENTRUM (BY PRETORIA)

UNIQUE PAPER NO
UNIEKE VRAESTEL NR

(0)	(0)	(0)	(0)	(0)	(0)	(0)	(0)
(1)	(1)	(1)	(1)	(1)	(1)	(1)	(1)
(2)	(2)	(2)	(2)	(2)	(2)	(2)	(2)
(3)	(3)	(3)	(3)	(3)	(3)	(3)	(3)
(4)	(4)	(4)	(4)	(4)	(4)	(4)	(4)
(5)	(5)	(5)	(5)	(5)	(5)	(5)	(5)
(6)	(6)	(6)	(6)	(6)	(6)	(6)	(6)
(7)	(7)	(7)	(7)	(7)	(7)	(7)	(7)
(8)	(8)	(8)	(8)	(8)	(8)	(8)	(8)
(9)	(9)	(9)	(9)	(9)	(9)	(9)	(9)

For use by examination invigilator
Vir gebruik deur eksamenopsiener

IMPORTANT

- USE ONLY AN HB PENCIL TO COMPLETE THIS SHEET
- MARK LIKE THIS
- CHECK THAT YOUR INITIALS AND SURNAME HAS BEEN FILLED IN CORRECTLY
- ENTER YOUR STUDENT NUMBER FROM LEFT TO RIGHT
- CHECK THAT YOUR STUDENT NUMBER HAS BEEN FILLED IN CORRECTLY
- CHECK THAT THE UNIQUE NUMBER HAS BEEN FILLED IN CORRECTLY
- CHECK THAT ONLY ONE ANSWER PER QUESTION HAS BEEN MARKED
- DO NOT FOLD

BELANGRIK

- GEBRUIK SLEGS 'N HB POTLOOD OM HIERDIE BLAD TE VOLTOOI
- MERK AS VOLG
- KONTROLEER DAT U VOORLETTERS EN VAN REG INGEVUL IS
- VUL U STUDENTENOMMER VAN LINKS NA REGS IN
- KONTROLEER DAT U DIE KORREKTE STUDENTENOMMER VERSTREK HET
- KONTROLEER DAT DIE UNIEKE NOMMER REG INGEVUL IS
- MAAK SEKER DAT NET EEN ALTERNATIEF PER VRAAG GEMERK IS
- MOENIE VOU NIE

PART 2 (ANSWERS/ANTWOORDE) DEEL 2

1	(1)	(2)	(3)	(4)	(5)
2	(1)	(2)	(3)	(4)	(5)
3	(1)	(2)	(3)	(4)	(5)
4	(1)	(2)	(3)	(4)	(5)
5	(1)	(2)	(3)	(4)	(5)
6	(1)	(2)	(3)	(4)	(5)
7	(1)	(2)	(3)	(4)	(5)
8	(1)	(2)	(3)	(4)	(5)
9	(1)	(2)	(3)	(4)	(5)
10	(1)	(2)	(3)	(4)	(5)
11	(1)	(2)	(3)	(4)	(5)
12	(1)	(2)	(3)	(4)	(5)
13	(1)	(2)	(3)	(4)	(5)
14	(1)	(2)	(3)	(4)	(5)
15	(1)	(2)	(3)	(4)	(5)
16	(1)	(2)	(3)	(4)	(5)
17	(1)	(2)	(3)	(4)	(5)
18	(1)	(2)	(3)	(4)	(5)
19	(1)	(2)	(3)	(4)	(5)
20	(1)	(2)	(3)	(4)	(5)
21	(1)	(2)	(3)	(4)	(5)
22	(1)	(2)	(3)	(4)	(5)
23	(1)	(2)	(3)	(4)	(5)
24	(1)	(2)	(3)	(4)	(5)
25	(1)	(2)	(3)	(4)	(5)
26	(1)	(2)	(3)	(4)	(5)
27	(1)	(2)	(3)	(4)	(5)
28	(1)	(2)	(3)	(4)	(5)
29	(1)	(2)	(3)	(4)	(5)
30	(1)	(2)	(3)	(4)	(5)
31	(1)	(2)	(3)	(4)	(5)
32	(1)	(2)	(3)	(4)	(5)
33	(1)	(2)	(3)	(4)	(5)
34	(1)	(2)	(3)	(4)	(5)
35	(1)	(2)	(3)	(4)	(5)

36	(1)	(2)	(3)	(4)	(5)
37	(1)	(2)	(3)	(4)	(5)
38	(1)	(2)	(3)	(4)	(5)
39	(1)	(2)	(3)	(4)	(5)
40	(1)	(2)	(3)	(4)	(5)
41	(1)	(2)	(3)	(4)	(5)
42	(1)	(2)	(3)	(4)	(5)
43	(1)	(2)	(3)	(4)	(5)
44	(1)	(2)	(3)	(4)	(5)
45	(1)	(2)	(3)	(4)	(5)
46	(1)	(2)	(3)	(4)	(5)
47	(1)	(2)	(3)	(4)	(5)
48	(1)	(2)	(3)	(4)	(5)
49	(1)	(2)	(3)	(4)	(5)
50	(1)	(2)	(3)	(4)	(5)
51	(1)	(2)	(3)	(4)	(5)
52	(1)	(2)	(3)	(4)	(5)
53	(1)	(2)	(3)	(4)	(5)
54	(1)	(2)	(3)	(4)	(5)
55	(1)	(2)	(3)	(4)	(5)
56	(1)	(2)	(3)	(4)	(5)
57	(1)	(2)	(3)	(4)	(5)
58	(1)	(2)	(3)	(4)	(5)
59	(1)	(2)	(3)	(4)	(5)
60	(1)	(2)	(3)	(4)	(5)
61	(1)	(2)	(3)	(4)	(5)
62	(1)	(2)	(3)	(4)	(5)
63	(1)	(2)	(3)	(4)	(5)
64	(1)	(2)	(3)	(4)	(5)
65	(1)	(2)	(3)	(4)	(5)
66	(1)	(2)	(3)	(4)	(5)
67	(1)	(2)	(3)	(4)	(5)
68	(1)	(2)	(3)	(4)	(5)
69	(1)	(2)	(3)	(4)	(5)
70	(1)	(2)	(3)	(4)	(5)

71	(1)	(2)	(3)	(4)	(5)
72	(1)	(2)	(3)	(4)	(5)
73	(1)	(2)	(3)	(4)	(5)
74	(1)	(2)	(3)	(4)	(5)
75	(1)	(2)	(3)	(4)	(5)
76	(1)	(2)	(3)	(4)	(5)
77	(1)	(2)	(3)	(4)	(5)
78	(1)	(2)	(3)	(4)	(5)
79	(1)	(2)	(3)	(4)	(5)
80	(1)	(2)	(3)	(4)	(5)
81	(1)	(2)	(3)	(4)	(5)
82	(1)	(2)	(3)	(4)	(5)
83	(1)	(2)	(3)	(4)	(5)
84	(1)	(2)	(3)	(4)	(5)
85	(1)	(2)	(3)	(4)	(5)
86	(1)	(2)	(3)	(4)	(5)
87	(1)	(2)	(3)	(4)	(5)
88	(1)	(2)	(3)	(4)	(5)
89	(1)	(2)	(3)	(4)	(5)
90	(1)	(2)	(3)	(4)	(5)
91	(1)	(2)	(3)	(4)	(5)
92	(1)	(2)	(3)	(4)	(5)
93	(1)	(2)	(3)	(4)	(5)
94	(1)	(2)	(3)	(4)	(5)
95	(1)	(2)	(3)	(4)	(5)
96	(1)	(2)	(3)	(4)	(5)
97	(1)	(2)	(3)	(4)	(5)
98	(1)	(2)	(3)	(4)	(5)
99	(1)	(2)	(3)	(4)	(5)
100	(1)	(2)	(3)	(4)	(5)
101	(1)	(2)	(3)	(4)	(5)
102	(1)	(2)	(3)	(4)	(5)
103	(1)	(2)	(3)	(4)	(5)
104	(1)	(2)	(3)	(4)	(5)
105	(1)	(2)	(3)	(4)	(5)

106	(1)	(2)	(3)	(4)	(5)
107	(1)	(2)	(3)	(4)	(5)
108	(1)	(2)	(3)	(4)	(5)
109	(1)	(2)	(3)	(4)	(5)
110	(1)	(2)	(3)	(4)	(5)
111	(1)	(2)	(3)	(4)	(5)
112	(1)	(2)	(3)	(4)	(5)
113	(1)	(2)	(3)	(4)	(5)
114	(1)	(2)	(3)	(4)	(5)
115	(1)	(2)	(3)	(4)	(5)
116	(1)	(2)	(3)	(4)	(5)
117	(1)	(2)	(3)	(4)	(5)
118	(1)	(2)	(3)	(4)	(5)
119	(1)	(2)	(3)	(4)	(5)
120	(1)	(2)	(3)	(4)	(5)
121	(1)	(2)	(3)	(4)	(5)
122	(1)	(2)	(3)	(4)	(5)
123	(1)	(2)	(3)	(4)	(5)
124	(1)	(2)	(3)	(4)	(5)
125	(1)	(2)	(3)	(4)	(5)
126	(1)	(2)	(3)	(4)	(5)
127	(1)	(2)	(3)	(4)	(5)
128	(1)	(2)	(3)	(4)	(5)
129	(1)	(2)	(3)	(4)	(5)
130	(1)	(2)	(3)	(4)	(5)
131	(1)	(2)	(3)	(4)	(5)
132	(1)	(2)	(3)	(4)	(5)
133	(1)	(2)	(3)	(4)	(5)
134	(1)	(2)	(3)	(4)	(5)
135	(1)	(2)	(3)	(4)	(5)
136	(1)	(2)	(3)	(4)	(5)
137	(1)	(2)	(3)	(4)	(5)
138	(1)	(2)	(3)	(4)	(5)
139	(1)	(2)	(3)	(4)	(5)
140	(1)	(2)	(3)	(4)	(5)

Specimen only